

Author Proof Review

Electrical Properties of Acupuncture Points and Meridians: A Systematic Review

Andrew C. Ahn,^{1,2,3*} Agatha P. Colbert,⁴ Belinda J. Anderson,⁵ Ørjan G. Martinsen,^{6,7}
Richard Hammerschlag,⁸ Steve Cina,⁹ Peter M. Wayne,¹ and Helene M. Langevin^{10,11}

¹Division for Research and Education in Complementary and
Integrative Medical Therapies, Harvard Medical School, Boston, Massachusetts

²Division of General Medicine and Primary Care, Beth Israel Deaconess Medical Center,
Boston, Massachusetts

³Center for Biomedical Engineering, Massachusetts Institute of Technology,
Cambridge, Massachusetts

⁴Helfgott Research Institute, National College of Natural Medicine, Portland, Oregon

⁵Pacific College of Oriental Medicine, New York, New York

⁶Department of Physics, University of Oslo, Oslo, Norway

⁷Department of Clinical and Biomedical Engineering, Rikshospitalet, Oslo, Norway

⁸Oregon College of Oriental Medicine, Portland, Oregon

⁹New England School of Acupuncture, Watertown, Massachusetts

¹⁰Department of Neurology, University of Vermont, Burlington, Vermont

¹¹Department of Orthopaedics and Rehabilitation, University of Vermont,
Burlington, Vermont

According to conventional wisdom within the acupuncture community, acupuncture points and meridians are special conduits for electrical signals. This view gained popularity after anecdotal reports and clinical studies asserted that these anatomical structures are characterized by lower electrical impedance compared to adjacent controls. To ascertain whether evidence exists to support or refute this claim, we conducted a systematic review of studies directly evaluating the electrical characteristics of acupuncture structures and appropriate controls. We searched seven electronic databases until August 2007, hand-searched references, and consulted technical experts. We limited the review to primary data human studies published in English. A quality scoring system was created and employed for this review. A total of 16 articles representing 18 studies met inclusion criteria: 9 examining acupuncture points and 9 examining meridians. Five out of 9 point studies showed positive association between acupuncture *points* and lower electrical resistance and impedance, while 7 out of 9 meridian studies showed positive association between acupuncture *meridians* and lower electrical impedance and higher capacitance. The studies were generally poor in quality and limited by small sample size and multiple confounders. Based on this review, the evidence does not conclusively support the claim that acupuncture points or meridians are electrically distinguishable. However, the preliminary findings are suggestive and offer future directions for research based on in-depth interpretation of the data. Bioelectromagnetics 00:1–12, 2008. © 2008 Wiley-Liss, Inc.

Key words: impedance; resistance; capacitance; skin; electrodermal

Grant sponsor: National Center for Complementary Alternative
Medicine (NCCAM); Grant number: K23-AT003238.

Received for review 12 October 2007; Final revision received 28
November 2007

*Correspondence to: Andrew C. Ahn, Harvard Medical School,
Division for Research and Education in Complementary and
Integrative Medical Therapies, 401 Park Drive Suite 22A-West,
Boston, MA 02215. E-mail: aahn@hms.harvard.edu

DOI 10.1002/bem.20403
Published online in Wiley InterScience
(www.interscience.wiley.com).

BEM07-0187.R1(20403)

BACKGROUND

Despite hundreds of mechanistic and clinical studies in acupuncture, the fundamental tenets of acupuncture—the point and meridian—are poorly understood. Classic Chinese medical theory recognizes about 361 points, said to be located on 14 main meridians connecting the body. The 14 main meridians are associated with specific organs and serve as pathways for the flow of “vital energy” or *qi* [Birch and Felt, 1999; Kaptchuk, 2002]. Within the acupuncture community, it is a commonly held opinion that these acupuncture structures are special conduits for electrical signals [Brewitt, 1995]. This view gained popularity as early as the 1950s when anecdotal reports and clinical studies from China, Japan, France, Germany, and the United States asserted that acupuncture points and meridians are distinguishable by their lower electrical impedance compared to adjacent controls [Royal and Royal, 1991; Brewitt, 1995]. As this view gained traction, devices such as acupuncture point locators and electrodiagnostic devices became commercially available to “scientifically” assist the clinicians in diagnosis and treatment delivery.

The fundamental premise by which these devices were developed, however, has always been viewed with considerable skepticism from the conventional scientific community. Confounding factors, such as skin moisture, electrode pressure, stratum corneum thickness, electrode polarization, and other factors have led many to assert that the reportedly distinct electrical characteristics are attributable to external factors and/or artifacts and not to the acupuncture point or meridian. To this day, no systematic evaluation of these studies has been conducted.

This article aims to systematically review and summarize the studies evaluating the electrical properties of acupuncture points and meridians. This review assesses whether sufficient evidence can support or refute the claim that acupuncture structures are electrically distinct. To maintain focus, we limited the review to human studies. This review does not include studies that assess the clinical significance of these electrical measures, focus on the temporal behavior of electrical measurements at acupuncture structures alone, or offer theoretical explanation for this reported association without empirical data. To make this review as objective as possible, we created and employed a scoring system to characterize the quality of the studies that met review criteria.

EVIDENCE ACQUISITION

Search Strategy

We sought studies that evaluated the electrical properties of acupuncture points and meridians com-

pared to appropriate controls. We searched seven electronic databases, including PubMed, Cochrane Library Database, AltHealthWatch (EBSCO Host), Allied and Complementary Database (AMED), Biosis, EMBASE, and Scientific Citation Index Expanded for dates ranging from the databases inception to August 2007 for all seven databases. We also searched the Conference Paper Index and Dissertation Citation but found no useful citations or references in these two databases. Searches were limited to the English language due to translation challenges.

Titles, abstracts, and keyword lists of the seven electronic databases were searched using the following MeSH terms: acupuncture, acupoint, and meridian crossed with the terms: impedance, resistance, conductivity, conductance, admittance, susceptance, potential, capacitive, capacitance, electropermeable, electrophysiologic, electrodermal, electrodiagnostic, and electrodiagnosis. The MeSH terms were exploded to maximize yield and to capture all possible relevant studies. We limited the search to “Human” or “English language” studies, if such search options were available. Where possible, “related articles” function was used to identify additional references. We referred to popular acupuncture texts to identify other potential studies, hand-searched all relevant references from papers and texts, and contacted experts in the field to identify any additional references.

Study Selection

For each database citation, we read the full abstract to determine whether acupuncture points or meridians were measured electrically. When the abstract lacked sufficient detail or was simply absent, the full text article was acquired for citations containing titles or abstracts indicating involvement of electrical stimulation or device. Full text articles containing primary data on electrical measures at points and/or meridians as well as controls were maintained in the review and further evaluated for methodological quality. Controls were defined as (1) areas not containing an acupuncture point or meridian or (2) areas within the vicinity of a point or meridian. Based on the second definition, studies containing only topographic profiles of electrical measures around an acupuncture point were maintained in the review. Non-English publications and studies with animals were excluded. We did not include studies that evaluated the clinical significance of electrical measures, reported electrical measurements without appropriate controls, or speculated on the mechanistic reasons for these electrical characteristics at acupuncture points or meridians without empirical data.

Full-text articles were further screened with a predetermined set of scoring criteria and eliminated if they scored less than three out of the possible ten points. This strategy was employed based on the assumption that poor quality studies would unlikely contribute meaningfully to our understanding of acupuncture points and meridians.

Development and Application of the Scoring Instrument

To assess study quality in a manner that minimizes subjective, a set of scoring criteria was created for this review. The criteria were developed by a multidisciplinary panel of five experts, representing the relevant disciplines of acupuncture, biomedicine, electrophysiology, biophysics, electrical engineering, and survey methodology. Each panelist first produced a list of items he/she considered important for evaluating electrical characteristics at acupuncture sites. The items were combined into one large list and resent to all panelists for reevaluation. Items with low face validity were eliminated by consensus, with the understanding that the instrument should be comprehensive yet flexible enough to account for study diversity. The items were presented in a yes/no/partial format to minimize subjectivity.

Based on panelists' feedback, a preliminary scoring instrument was created and subsequently tested on selected articles by three academic clinicians—two of whom were not on the panel of experts. Problems in clarity and/or applicability of each item were identified, and wording was modified to address these concerns. The panelists categorized the items into ten domains: subjects and settings, site selection, controls, electrode, confounding variables, instruments, electrical input, measurements, blinding, and result/statistical analysis. Each domain has a value of one point, yielding a total of ten points for the scoring system. The final instrument was resent to panelists for final approval. (The final scoring instrument can be viewed at http://osher.hms.harvard.edu/pu_general_pub.asp.)

Two physicians (AA and AC) with backgrounds in acupuncture and electrophysiology independently reviewed and scored the qualifying studies. These reviewers were not blinded to the study title or authors' names. Each item within the scoring criterion was discussed until a final agreement was reached. For those items where an agreement could not be reached, a third party evaluator was involved to achieve consensus. Relevant data were extracted from the studies and aggregated in tabular form.

EVIDENCE SYNTHESIS

Selection Results

From 1663 citations, we identified 320 with potential relevance to this review (see Fig. 1). After obtaining and reading the full texts, we identified 50 articles that actively measured electrical parameters at the skin. Of these articles, 10 were excluded due to lack of a control [Nakatani, 1956, 1986; Nakatani and Yamashita, 1977; Motoyama et al., 1984; Motoyama, 1986; Ionescutirgoviste et al., 1987; Cho and Chun, 1994; Comunetti et al., 1995; Cheng et al., 2000; Fang et al., 2004]; 16 were excluded due to poor quality as defined by a quality score of less than three out of possible ten points [Bergsmann and Woolley-Hart, 1973; Noordergraaf and Silage, 1973; Brown et al., 1974; Ghaznavi, 1974; Roppel and Mitchell, 1975; Becker, 1976; Shenberger, 1977; Eory, 1984; Zhu et al., 1984; Croley, 1986; Nansel and Jansen, 1988; Zhu et al., 1988; Chen, 1996; Eickhorn and Schimmel, 1999; Lu et al., 1999; Halek, 2000]; and 6 were excluded for using electrical parameters to initially define acupuncture points or meridians [Wulfson and Warren, 1976; Prokhorov et al., 2000a,b, 2006; Lee et al., 2003; Zhang et al., 2004]. Sixteen articles representing 18 studies were maintained in the review and evaluated in detail. Nine studies evaluated the acupuncture point [Reichmanis et al., 1975, 1976; Hyvarinen and Karlsson, 1977; McCarroll and Rowley, 1979; Poon et al., 1980; Falk et al., 2000; Pearson et al., 2007], while the other nine evaluated the acupuncture meridian [Reichmanis et al., 1977a,b, 1979; Hu et al., 1992; Zhang et al., 1999a; Martinsen et al., 2001; Johng et al., 2002; Lee et al., 2003; Ahn et al., 2005].

Acupuncture Points: Data Summary

Most studies evaluating the acupuncture points were of poor quality and published in journals with low citation index (see Table 1). All studies tested the hypothesis that acupuncture points are areas of lower resistance or impedance. Overall, the sample sizes were small (mean $N = 13$), and study participants were mostly healthy. DC or low frequency currents were commonly used and thus electrical resistance or conductance was the parameter most frequently evaluated. In four cases, the choice of controls was inadequately justified and could have easily influenced the outcome [Reichmanis et al., 1975, 1976; Falk et al., 2000; Pearson et al., 2007]. All studies employed a monopolar electrode arrangement with a smaller active electrode over the point(s) of interest and a larger reference electrode frequently held in the hand by the study participant. In addition, the studies tended to limit

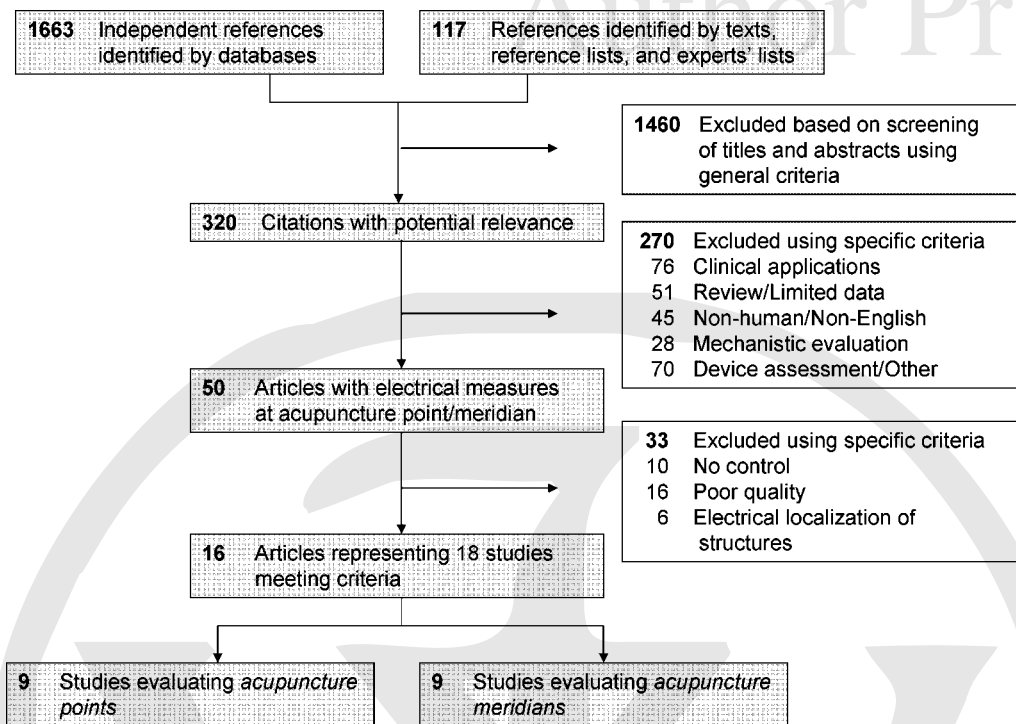

Fig. 1. Study flow.

their evaluation to the upper extremities. Only three studies evaluated acupoints not located on the arms and evaluated points on the ear and forehead as well [Hyvarinen and Karlsson, 1977; Falk et al., 2000; Pearson et al., 2007].

While five out of nine studies showed a positive association between acupuncture points and decreased electrical impedance/resistance, the higher quality studies showed little to no association. Pearson et al.'s study [2007], the highest rated study, used two devices—one with a DC current and the other with a 100 Hz AC current—to determine the resistance/impedance at an (1) acupuncture point, (2) non-acupuncture point located *on* a meridian, and (3) a non-acupuncture point *not* on a meridian. These three points were identified on several body sites that included the palm (PC8), forehead (GB14), and fourth finger (TW1). Only acupoint GB14 showed any significant difference with the non-meridian/non-acupuncture control and, furthermore, this difference was seen only with the 100 Hz device. The meridian points, on the other hand, demonstrated significant (or near significant) decrease in electrical impedance compared to the non-meridian control in all three body sites with the exception of the DC resistance at acupoint PC8.

In evaluating acupuncture points, two general strategies were taken. One strategy was to first identify the acupuncture point/control and then meas-

ure the electrical resistance or conductance [McCarroll and Rowley, 1979; Pearson et al., 2007]. The other strategy was to scan or survey the skin to identify low resistance areas and subsequently see if the areas coincided with acupuncture points [Hyvarinen and Karlsson, 1977]. The studies that resorted to the latter method tended to have more positive results than those taking the former approach. This implies that the inappropriate or inaccurate identification of points might have contributed to the discrepant findings.

The techniques applied in these studies were remarkably diverse, particularly with respect to probe type. Reichmanis in 1975 wheeled a circular steel electrode 0.2 cm in diameter along the meridian and control line [Reichmanis et al., 1975], whereas Reichmanis in 1976 used a 6 × 6 array of 2 mm diameter steel electrodes to produce a topographic representation of electrical conductance [Reichmanis et al., 1976]. In contrast, Hyvarinen used two concentric electrodes—a 0.5 mm diameter inner electrode and a 2.5 mm diameter outer ring electrode that served as a control [Hyvarinen and Karlsson, 1977], while Poon et al. [1980] used an adhesive, conducting tape with high voltage intensities. This diversity in techniques accounts for why the results are neither readily comparable between studies nor generalizable to all low-impedance points and controls on the human body.

TABLE 1. [Studies^{Q1}](#)—Electrical Characterization of Acupuncture Points

References ^{Q2}	Design	Sample	Electrical current	Electrode	Site of testing	Control	Results	Evidence direction	Quality score (out of 10)
Reichmanis et al. [1975]	Identified maximal conductance points within 1 cm ² area at acupoint and control and compared “fractional increase” in conductance	7	DC, ~ 1 μA	0.2 cm wide stainless steel wheel	17 acupoints on PC and LI meridian b/w metacarpophalangeal and elbow joint	“Nearby anatomically similar location”	2 out of 6 PC points and 3 out of 11 LI points had significant fractional increase in conductance in all 7 subjects	+	4
Reichmanis et al. [1976]	Obtained topographic conduction profiles at acupoint and control, and compared conductance variance	10	DC, 2 V	0.2 cm 36 stainless steel rods in grid pattern 3.5 × 2.5 cm	10 acupoints TB 4–9, Lu 5–8 (on forearm)	2.5 × 2.5 cm nearby point “as close as feasible”	76/100 acupoint loci showed increased conductance variance compared to control >5 subjects with increased conductance variance at all 10 acupoints	+	4
Hyvarinen and Karlsson [1977]	Identified low resistance points on forearm and hand using concentric electrode	5 healthy male medical students	DC, 6.7 V	0.5 mm diameter circular electrode with 2.5 mm concentric reference electrode	Forearm, hands, ears	Surrounding skin (2.5 mm radius)	Reproducible low resistance points were identified on hand and ears. Points resemble acupoints in location	+	3
Hyvarinen and Karlsson [1977]	Measured impedance of low resistance points and the area within their vicinity	5 healthy male medical students	DC, AC, 500, 1000 Hz	0.5 mm silver wire electrode	Forearm, ears	Surrounding skin (2.5 mm radius)	Impedance per unit area was 50- to 100-fold lower at low resistance points compared to adjacent skin—10–100 kΩ vs. 2–3 MΩ, respectively	+	3
McCarroll and Rowley [1979]	Determined whether impedance minimum existed in a 5 × 5 grid around acupoint	8	AC, 1 kHz, 4.5 μA	1 mm silver wire rod, chlorinated	7 acupoints on hand/arm	—	4 out of 32 collected sets showed decreased skin impedance upon replication Data showed temporal variability	–	4
Poon et al. [1980]	Identified “electropermeable” points using tape electrode	9	AC, 0.5 Hz, 0–18 V	3 × 1 inch epiductive tape electrode	Forearm—along Lu, PC meridian	N/A	Conductive “spots” on forearm were identified. Spots lie along meridian, but not clearly associated with acupoints. No general pattern across subjects	±	3
Falk et al. [2000]	Measured 2 × 2 grid impedances at “active” vs. control zones and compared minimum impedances b/w zones	34 b/o cocaine abuse on methadone; 17 M, 17 F	AC, 5 Hz, 2.5 μA	1 mm Ag/AgCl probe	4 active ear zones (shenmen, sympathetic, liver, lung)	4 control zones on helix of ear	Lowest impedance values found within active zones were significantly lower than those within control zones. Active 1.36 vs. Cont 1.97 MΩ (P < .05)	+	6
Pearson et al. [2007]	Measured resistance at three sites: acupoint, adjacent meridian point, and non-meridian point	20 healthy adults; 6 M, 14 F	DC, 1.1 μA	4.57 mm probe tip	PC 8, TW1, GB14 (palm, tip of finger, forehead, respectively)	Nearby control sites—site on related meridian and site off meridian	No significant differences in resistance were noted between acupuncture point and non-acupuncture points at all 3 sites	–	7
Pearson et al. [2007]	Measured impedance at three sites: acupoint, adjacent meridian point, and non-meridian point	20 healthy adults; 6 M, 14 F	AC, 100 Hz, <14.2 μA	3.56 mm metal tip	PC 8, TW1, GB14	Nearby control sites—site on related meridian and site off meridian	Significant decrease in impedance noted only for GB 14 (P = .02)	–	7

Acupuncture Points: Interpretation

With the small sample sizes and overall poor quality of the studies, no definitive conclusions can be drawn about the electrical characteristics of acupuncture points. Because the studies generally limited their evaluation to the upper extremity and to healthy individuals, the lack of data is especially pronounced for non-upper-extremity body sites and for unhealthy conditions. Nevertheless, certain useful information can be extracted and interpreted from the studies if taken as a whole. Some of this information might explain the discrepancy in results.

Although researchers may disagree on the appropriateness of equating low electrical-resistance areas on the skin to acupuncture points, many studies support the existence of loci with minimum resistance (at least on the arm). These loci were described as being approximately a millimeter range in diameter (although most studies did not adequately describe the methods used to measure the dimensions). Hyvarinen and Karlsson [1977] reported low-resistance areas approximately 1.5 mm in diameter on the forearm, while Poon et al. [1980] described 0.05 mm punctate, forearm lesions that became progressively larger as ~ 10 V was delivered to the skin. Other studies (not included in our review) reported similar findings: Kaslow and Fraden^{Q3} claimed low resistance points were 1 mm in diameter [Kaslow, 1975]; Croley [1986] reported a low resistance area with 1.5–2 mm in diameter at acupoint LI4 (on dorsum of hand); while Becker [1976] displayed a conductive maxima that was approximately 4 mm in diameter.

Conceivably, these sizes vary with body site and may be smaller at areas with greater contour. This may explain why Hyvarinen's method consistently identified low resistance points at the finger tips and ears but not in other areas of the hand, since his apparatus is designed to detect smaller-diameter points. He used two mounted, concentric electrodes—a 0.5 mm diameter central electrode and a 2.5 mm diameter outer ring electrode—and identified areas where the resistances were significantly different at skin sites contacted by the two electrodes [Hyvarinen and Karlsson, 1977]. Whether these low resistance points correlate with acupuncture points or possess any physiologic significance remains an area of contention. The only attempt to correlate anatomical data with high conductive skin areas reported a lack of spatial coincidence with hair follicles [Poon et al., 1980].

Electrical skin measurements appear to vary significantly across body sites. Impedance graphs revealed that the mean impedance of PC6 at 1 kHz was approximately 500 k Ω while that of PC5 (a few cm

away) was approximately 1300 k Ω [McCarroll and Rowley, 1979]. The median impedances at acupoint TW1 differed from the non-acupoint control (several inches away) by 5611 k Ω for the DC measurements (acupoint—12,493 k Ω , control 6993 k Ω) and 483 k Ω for the AC measurements (acupoint—3496 k Ω , control 3979 k Ω) [Pearson et al., 2007]. Conductance values obtained from a wheel electrode fluctuated significantly along the LI meridian of the arm, and the graphical representation of the conductance showed multiple peaks and dips along the wheel trajectory [Becker, 1976]. This spatial variability in impedance highlights the importance in obtaining measurements in a limited geographical area. In agreement with this observation, Reichmanis et al. [1975] contended that acupoints are *local* impedance minima and not *absolute minima*. Equating acupoints to impedance minima across a large region of skin may be an unnecessarily strong criterion. As seen in Pearson et al.'s study [2007], the controls were up to four to five centimeters apart and may account for the inconsistent differences in impedance values across conditions (acupoint vs. control). A similar confounder may have occurred in McCarroll and Rowley's study [1979] since the dimensions of the 5 \times 5 impedance grid were never described. Whether the absence of a single impedance minimum is attributed to the spatial variability across a large region or to the true absence of a local impedance minimum remains unclear.

Finally, the choice of testing site appears to play a significant role in affecting the study outcome. The localization of acupuncture points, in particular, is pivotal for the proper evaluation of the electrical characteristics of an "acupoint." Yet establishing the proper location is more difficult than generally recognized. Standard textbooks rely on palpation and proportional measurements to determine acupoint locations, but this technique, in truth, provides a substantial amount of wiggle room and can span up to 1 cm in diameter [Aird et al., 2002]. For this reason, acupuncture styles and practitioners can frequently disagree on the exact location of the acupuncture points [Aird et al., 2000; Coyle et al., 2000]. This difficulty in localization may explain why studies that electrically survey the skin around the acupuncture point tend to show a positive association, while those studies that predetermined the acupoint location prior to electrical measurements do not.

The choice of general body regions may also play a major role. For instance, the decision of Pearson et al. [2007] to investigate areas with higher sweat gland density—the forehead (GB14) and palm (PC8)—may have contributed to the lack of association between acupuncture point and electrical impedance. Since

electrical impedances at low frequencies are influenced by ionic shunting through sweat ducts, the impedance values in these areas may be more representative of sweat gland density than other physiologic processes that might be associated with acupuncture point, if any exist [Grimnes, 1984].

Acupuncture Meridians: Data Summary

Compared to the acupuncture point studies, the meridian studies were generally of higher quality, enrolled more subjects, were more technically sophisticated, and showed more positive associations with various electrical characteristics (see Table 2). Seven out of nine studies showed a positive association, one was mixed, while one study showed no significant association. The overall study quality, while better than that of the acupuncture point studies, was nevertheless flawed with an average quality score of 4.5 out of 10. Furthermore, the study sample sizes were generally small (mean $N=23$), all participants were healthy individuals, and all studies evaluated the upper extremity with the exception of Ahn et al. [2005] and Hu et al. [1992] studies where the lower extremity and trunk [Hu et al., 1992] were evaluated.

The techniques used in the meridian studies, much like the point studies, were remarkably diverse. Both two electrode and four electrode systems were used. Aside from Hu et al.'s study [1992], the two electrode system involved bipolar electrode arrangements utilizing two electrodes equal in size. This arrangement ensured that the resistance or impedance was not dominated by one electrode. Reichmanis et al. [1977a,b, 1979] employed 1 cm carbon impregnated conducting rubber electrodes, and [Martinsen \[2001\]^{Q7}](#) used a linear array of 0.5 mm steel electrodes 1 mm apart. Studies employing four electrode systems have used metal pipes filled with saline [Zhang et al., 1999a], gold plated copper cylinders [Johng et al., 2002], and gold plated acupuncture needles [Ahn et al., 2005].

In contrast to the point studies, the meridian studies tended to address polarizing effects at the electrode. Four electrode methods have been used with the explicit intention of bypassing polarizing effects at the current delivering electrodes [Zhang et al., 1999b; Johng et al., 2002; Ahn et al., 2005]. Hu et al.'s [1992] use of "pulsed" voltages might have minimized the polarization effects at the skin and electrode, although the details of the pulse length and current measurement were not mentioned. Additionally, the meridian studies tended to use sophisticated calculations to determine the reactive effects of the biological tissue under examination. To help determine the resistive and capacitive components, Johng obtained impedance values across multiple frequencies from 0.1 to 14 kHz

and identified a circuit model (a capacitor in series with a parallel RC circuit) that best fit the data (Fig. 2A). Reichmanis recorded the time-dependent changes in current as a maximum 1 V DC input was administered to the electrodes. She performed Laplacian analyses to transform the current measurements from the time-domain to the frequency domain and derived the resistive and capacitive components based on a predetermined circuit (a resistor in series with a parallel RC circuit; Fig. 2B).

With the exception of two studies, acupuncture meridians were described as yielding lower electrical impedances than adjacent controls. In one of the exceptions, lower impedance values were observed at the Pericardium channel but not at the Spleen channel located on the leg [Ahn et al., 2005]. In the other exception, no lines of higher electrical admittance were detected on the arm to correspond with an acupuncture meridian [Martinsen et al., 2001]. The studies, otherwise, generally agreed that acupuncture meridians are characterized by lower impedances. Additionally, Reichmanis and Johng reported higher capacitive effects at the acupuncture meridians compared to adjacent controls [Lee et al., 2003]. Furthermore, Lee detected a directional bias with charge flow along the meridian. When DC resistance between two acupoints (LI4 and LI11) was compared to the DC resistance between an acupoint (LI4) and a non-acupoint control (1 cm apart from LI11), the resistance was not only comparatively decreased between the two acupoints, but was also reduced when electrical charge flowed proximally between the two acupoints compared to flowing distally between them. No such directional bias was found between the acupoint and non-acupoint. According to Lee, this preferential flow of charge is consistent with acupuncture theory which describes qi as flowing proximally along the LI meridian.

Acupuncture Meridians: Interpretation

Compared to the point studies, as stated above, the meridian studies had a generally more sophisticated design and were slightly higher in quality. Furthermore, the studies tended to conclude that meridian sites were indeed characterized by lower electrical impedance compared to adjacent controls. Multiple reasons may explain this disparity in results between the meridian and point studies. First, the meridian studies used methods that accounted for polarizing effects while the point studies frequently did not. DC and low frequency AC stimuli were commonly used in point studies, and the consequent polarizing effects may have disguised any possible electrical features that distinguish acupuncture points. Second, meridians are generally easier to locate than acupuncture points.

TABLE 2. Studies—Electrical Characterization of Acupuncture Meridians

References	Design	Sample	Electrical current	Electrode	Site of testing	Control	Results	Evidence direction	Quality score (out of 10)
Reichmanis et al. [1977a]	Calculated resistance between two acupoints on same meridian—bipolar electrodes	10	DC, 1 V max ampl, 10 μ s rise time, 100 μ s duration	1 cm carbon impregnated conducting rubber	L14–L112	1.5 cm medial and lateral parallel control	Circuit model predetermined ^a —normalized values Meridian R1 (2–200 k Ω) R2 (100–5000 k Ω) C (50–1500 pF) 1.0 1.0 1.0 1.0 Control 1.9, 1.77 ($P < .05$) 1.15, 1.45 ($P > .05$) 0.93, 0.95 ($P > .05$)	+	5
Reichmanis et al. [1977b]	Calculated resistance, capacitance between two adjacent acupoints—bipolar electrodes	10	DC, 1 V max ampl, 10 μ s rise time, 100 μ s duration	1 cm carbon impregnated conducting rubber	H3–H4	1.5 cm medial and lateral parallel control	R1 R2 C 8.6 471 489 Control ^a 44.8, 55.6 k Ω 1264, 1779 k Ω 168, 326 pF (F -test, $P < .05$)	+	5
Reichmanis et al. [1979]	Calculated resistance, capacitance between two non-acupoints on same meridian—bipolar electrodes	10	DC, 1 V max ampl, 10 μ s rise time, 100 μ s duration	1 cm carbon impregnated conducting rubber	1.5 cm distal to H3—1.5 cm proximal to H4	1.5 cm medial and lateral parallel control	R1 R2 C 32.8 1380 314 Control ^a 41.6, 50.2 k Ω ($P < .05$) 2596, 2093 k Ω ($P < .05$) 127, 99 pF ($P < .05$ for one of two controls)	+	5
Hu et al. [1992]	Identified sites of low resistance by scanning laterally across each channel	68 healthy volunteers	DC, "pulsed" 0–50 V	1 mm pure silver tip	All 14 meridians	N/A	83.3 and 96% of low skin impedance points (LSIP) found within 3 and 5 mm vicinity of acupuncture meridians. Non-linear voltage-current relationship seen with LSIP, but not non-LSIP points	+	3
Zhang ⁰⁴ et al. [1999]	Measured impedance along Pericardium using four electrode method	12 healthy persons 5 M, 7 F	AC, 5 kHz 38 μ A	4 mm metal pipes with saline cotton	Pericardium channel centered around PC3	2–3 cm "outside meridian"	Impedance No low impedance lines found	+	4
Martinsen et al. [2001]	Surveyed skin with a linear array of electrodes to find low resistance pathways	20 volunteers 10 M, 10 F	AC, 418 Hz, 100 mV	0.5 mm 16 steel electrodes in linear array	Volar aspect of forearm	N/A		–	4
Johng et al. [2002]	Measured impedance across multiple frequencies using four-electrode method	30 healthy persons, 25 M, 5 F	AC, 0.1–14 kHz, 1.0 μ A, 0.6 V	4 mm Au plated Cu cylindeers	Pericardium channel centered around PC3	6–7 mm lateral parallel control	Derived model circuit ^b Meridian R C C' 1.83 0.09 0.46	+	4
Ahn ⁰⁵ et al. [2004]	Measured electrical impedance of meridian-associated connective tissue—four electrode method	23 healthy volunteers	AC, 3.3 kHz 20, 40, 80 μ A	0.25 mm gold plated needle 1 cm depth	Pericardium and Spleen meridian	0.8 cm medial and parallel to meridians	Impedance Pericardium Spleen 70.4 67.8 Control 4.32 k Ω 0.05 μ F 0.37 μ F Control 75.0 Ω ($P < .01$) 68.5 Ω ($P = .70$)	\pm	8
Lee ⁰⁶ et al. [2005]	Measured bi-directional resistance b/w two acupoints and b/w acupoint and non-acupoint	20 healthy volunteers 20 M	DC, 1.28 V	–	L14–L11	L1-4 to non-acupoint 1 cm away from L1-11	Higher conductivity between 2 acupoints compared to controls ($P < .05$) Conductivity with proximal directed currents greater than distal currents ($P < .01$)	+	3

^aSee Figure 2B.^bSee Figure 2A.

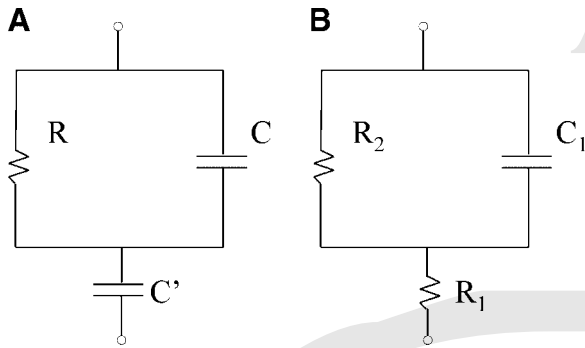

Fig. 2. Circuit models. **A:** Model circuit equivalent derived for Johng et al.'s study [2002]. **B:** Predetermined model circuit used for Reichmanis et al.'s studies [1977a,b,1979].

Meridians are larger structures that traverse longitudinally along an extremity or trunk, while points are smaller and distinct. In addition, bipolar electrode arrangements frequently used in meridian studies are generally larger and therefore less apt to miss an underlying meridian. Third, acupuncture points may in fact have no distinguishing electrical features, in contrast to the acupuncture meridian. As noted previously, high conductive areas were identified that tracked along the acupuncture meridian but did not coincide with known acupuncture points [Poon et al., 1980]. Also, low skin impedance points were consistently found all along the meridians and not limited to acupoints [Hu et al., 1992]. Similarly, significantly decreased impedance values were detected at meridian points but not at acupuncture points [Pearson et al., 2007]. As suggested by Reichmanis et al. [1975], it is possible that “some spurious acupuncture points were grafted on an otherwise valid system (acupuncture meridian).”

Despite the positive association reported in seven of nine studies, the evidence is inadequate to conclusively state that acupuncture meridians are sites of lower impedance and higher capacitance. Further studies are needed to confirm these findings and to determine if they are generalizable to areas of the body other than the arms. However, the rather uniform results are suggestive and offer initial speculations about the physiologic processes possibly involved in these localized findings.

Reichmanis' LaPlace Analysis studies are particularly valuable in providing some preliminary insights [Reichmanis et al., 1977a,b, 1979]. Reichmanis evaluated the resistive and capacitive components of three different sets of points: in order of increasing distance—two non-acupuncture points located on the same meridian (proximal to HT3 and distal to HT4), two adjacent acupuncture points (HT3 and HT4), and two

non-adjacent acupuncture points (LI4 and LI12). For each study, the resistive and capacitive effects at two control sites, 1 cm medial and lateral to the meridian segment, were also measured. Based on a predetermined circuit (Fig. 2B), R_1 , R_2 , and C values for each meridian and control segment were derived. R_1 was significantly decreased at the meridian segment compared to adjacent controls for all three studies. R_2 and C values were significantly decreased and increased, respectively, only for the acupoints HT3 and HT4 and for the two non-acupoints located on the Heart meridian. The lack of difference at LI4 and LI12 may be attributed to characteristic differences at the LI meridian or to the larger distance between LI4 and LI12. Compared to the Heart points used in the other two studies, the trajectory between LI4 and LI12 is larger and traverses two joints, the wrist and elbow joint. This larger distance may be responsible for the disparate results. If true, R_2 and C values may arise from deeper tissue layers. We would not expect R_2 and C values to change with distance if the epidermis (under the electrodes) was responsible.

The importance of deeper tissue layers is further supported, in part, by Martinsen et al.'s [2001] negative findings. His apparatus is designed to evaluate the most superficial layer of the epidermis, the stratum corneum. The low electrical frequency (418 Hz), small electrode size (0.5 mm diameter), and short interelectrode distances (1 mm) ensure that the charge currents travel superficially and yield admittance values reflective of the stratum corneum and not deeper subcutaneous layers. The inability to find lines of increased admittance may suggest that the stratum corneum is not involved in the decreased impedance reported in other studies.

Only one study suggested an anatomical association for the meridian [Ahn et al., 2005]. Based on earlier studies linking intermuscular connective tissue with acupuncture meridians [Langevin and Yandow, 2002], electrical impedance of meridian-associated loose connective tissue and adjacent muscle controls were evaluated. Significantly lower electrical impedance values were found at the Pericardium channel but not at the Spleen channel. This discrepancy was attributed to the presence of intermuscular connective tissue at the Spleen control. Further study is needed to determine whether the loose connective tissue is involved and possibly responsible for the lower resistance and higher capacitance reported in some studies.

Preferential flow of charge at the meridian was documented by a study of the Large Intestine meridian [Lee et al., 2003]. As mentioned previously, the flow of charge appeared to concur with acupuncture theory. Interestingly, this preferential flow was noted in another

study that failed to meet our review due to poor quality [Chen, 1996]. To our knowledge, no other study has evaluated this phenomenon which requires further evaluation before any conclusion can be reached.

CONCLUSION AND FUTURE DIRECTIONS

Based on our review of the English literature, the evidence does not conclusively support the claim that acupuncture points or meridians are electrically distinguishable. In general, the studies were of poor quality, involved small sample sizes, and limited their evaluation to the upper extremity and to healthy individuals. Future studies may consider extending these electrical measures to acupuncture points and meridians in other body sites (lower extremity, trunk, and ear) and to various clinical conditions.

Studies of electrical characteristics at acupuncture points were mixed in their conclusions. This disparity may stem from a large number of factors, including spatial variability in skin electrical impedance, sweat gland density, electrode polarization effects, and variable point locating techniques. To determine whether acupuncture points are electrically distinct, future studies should account for important confounders [Ahn and Martinsen, 2007] and consider adopting certain test conditions. Scanning methods to obtain topographic electrical impedance profiles around acupuncture points and controls may limit the possibility that the sites are inappropriately or inaccurately identified. Limiting the assessment to small geographical areas of skin may minimize the effects of spatial variability seen with skin impedance across large regions. Evaluating areas with low sweat gland density may minimize the potentially confounding effect of sweat glands on electrical impedance, and using electrodes approximately 1 mm in diameter will minimize the risk of missing the low impedance points. Newer imaging techniques, such as acoustic microscopy or optical coherence tomography, may be helpful in further identifying the local anatomy (e.g., sweat gland) that may affect electrical measures. Because electrical capacitance and potential measurements have not been appropriately evaluated, future studies may also consider obtaining these measures at acupuncture points and controls to acquire additional electrophysiological information.

While inadequate, the evidence is more supportive of the claim that acupuncture meridians are electrically distinct. The meridian studies were generally of higher quality and were more inclined to consider polarization effects than the point studies. While the results are suggestive, additional studies should be performed to determine whether the results

are replicable. Preliminary interpretation of the data suggests that deeper, subcutaneous tissue layers may be an important component in the increased capacitance and decreased resistance reported at acupuncture meridians. If so, future studies may consider using larger surface electrodes (~1 cm) separated by sufficient distance to minimize the contribution of superficial layers to the impedance or admittance values. Alternatively, they may use invasive electrodes. With the development of sophisticated impedance analyzers, frequency-related changes in impedance are relatively easy to perform and make this area of research ripe for further exploration.

This systematic review is limited to studies published in English and should not be considered an exhaustive representation of studies investigating the electrical properties of acupuncture structures. Evaluation of research published in other languages (e.g., Chinese, French, German, or Japanese) may generate different conclusions. Based on our limited sample of non-English studies (Chinese and French), however, the quality of studies does not appear to differ substantially across languages for this particular topic of interest.

Until better quality studies are performed, we are unable to determine whether acupuncture structures possess distinct electrical characteristics. Nevertheless, the preliminary evidence is encouraging and may contain clues to the physiologic nature of the elusive acupuncture point and meridian.

ACKNOWLEDGMENTS

The authors thank Min Park, MAOM LAC for assisting in database search and literature acquisition. This research was supported by grant number K23-AT003238 of the National Center for Complementary Alternative Medicine (NCCAM). Its contents are solely the responsibility of the authors and do not necessarily represent the official views of the National Center for Complementary and Alternative Medicine, National Institutes of Health.

REFERENCES

- Ahn AC, Martinsen OG. 2007. Electrical characterization of acupuncture points: Technical issues and challenges. *J Altern Complement Med* 13(8):817–824.
- Ahn AC, Wu J, Badger GJ, Hammerschlag R, Langevin HM. 2005. Electrical impedance along connective tissue planes associated with acupuncture meridians. *BMC Complement Altern Med* 5:10.
- Aird M, Coyle M, Cobbin DM, Zaslowski C. 2000. A study of the comparative accuracy of two methods of locating acupuncture points. *Acupunct Med* 18(1):15–21.

- Aird M, Cobbin DM, Rogers C. 2002. A study of the relative precision of acupoint location methods. *J Altern Complement Med* 8(5):635–642.
- Becker RO. 1976. Electrophysiological correlates of acupuncture points and meridians. *Psychoenergetic Syst* 1:105–112.
- Bergsmann O, Woolley-Hart A. 1973. Differences in electrical skin conductivity between acupuncture points and adjacent skin areas. *Am J Acupunct* 1:27–32.
- Birch SJ, Felt RL. 1999. *Understanding acupuncture*. London: Churchill Livingstone. p 89.
- Brewitt B. 1995. Quantitative analysis of Electrical Skin Conductance in diagnosis: Historical and current views of Bioelectric Medicine. *J Naturopathic Med* 6(1):66.
- Brown ML, Ulett GA, Stern JA. 1974. Acupuncture loci: Techniques for location. *Am J Chin Med* 1:67–74.
- Chen KG. 1996. Applying quantum interference to EDST medicine testing. *IEEE Eng Med Biol Mag* 15(3):64–66.
- Cheng GS, Zhu B, Xu RZ. 2000. Nonlinear resistance of ear points. *Int J Clin Acupunct* 2000. 11(3):187–190.
- Cho SH, Chun SI. 1994. The basal electrical skin resistance of acupuncture points in normal subjects. *Yonsei Med J* 35(4):464–474.
- Comunetti A, Laage S, Schiessl N, Kistler A. 1995. Characterisation of human skin conductance at acupuncture points. *Experientia* 51(4):328–331.
- Coyle M, Aird M, Cobbin DM, Zaslowski C. 2000. The Cun measurement system: An investigation into its suitability in current practice. *Acupunct Med* 18(1):10–14.
- Croley TE. 1986. Electrical acupuncture point conductance in the living compared to that in the dead. *Am J Acupunct* 14(1):57–60.
- Eickhorn R, Schimmel HW. 1999. Electrophysiological diagnosis at terminal points of acupuncture meridians. *J Biomed Ther* 17(3):111.
- Eory A. 1984. In-vivo skin respiration (CO₂) measurements in the acupuncture loci. *Acupunct Electrother Res* 9(4):217–223.
- Falk CX, Birch S, Avants SK, Tsau Y, Margolin A. 2000. Preliminary results of a new method for locating auricular acupuncture points. *Acupunct Electrother Res* 25(3–4):165–177.
- Fang Q, Bedi R, Ahmed B, Cosic I. 2004. Comparison of skin resistance between biological active points of left and right hands with various contact pressures. *Conf Proc IEEE Eng Med Biol Soc* 4:2995–2998.
- Ghaznavi C. 1974. Localization of acupuncture loci by electrical impedance measurements. Worcester, MA: Worcester Polytech. p 387.
- Grimnes S. 1984. Pathways of ionic flow through human skin in vivo. *Acta Derm Venereol* 64:93–98.
- Halek J. 2000. A method of local skin perfusion detection. *J Med Syst* 24(4):257–264.
- Hu X, Wu B, Huang X, Xu J. 1992. Computerized plotting of low skin impedance points. *J Tradit Chin Med* 12(4):277–282.
- Hyvarinen J, Karlsson M. 1977. Low-resistance skin points that may coincide with acupuncture loci. *Med Biol* 55(2):88–94.
- Ionescutirgoviste C, Pruna S, Bajenaru O. 1987. Measurement of acupuncture injury potential by acupunctometry. *Am J Acupunct* 15(3):233–238.
- Johng HM, Cho JH, Shin HS, Soh KS, Koo TH, Choi SY, Koo HS, Park MS. 2002. Frequency dependence of impedances at the acupuncture point Quze (PC3). *IEEE Eng Med Biol Mag* 21(2):33–36.
- Kapchuk TJ. 2002. Acupuncture: Theory, efficacy, and practice. *Ann Intern Med* 136(5):374–383.
- Kaslow AL. 1975. A new technique for acupuncture point finding and stimulation 28. *Am J Acupunct* 3(2):157–160.
- Langevin HM, Yandow JA. 2002. Relationship of acupuncture points and meridians to connective tissue planes. *Anat Rec* 269(6):257–265.
- Lee J, Kim D, Park I, Park H, Cho J. 2003. Characteristics of human skin impedance including at biological active points. *IEICE Trans Fundam Electron Commun Comput Sci* E86-A(6):1476–1479.
- Lu WA, Tsuei JJ, Chen KG. 1999. Preferential direction and symmetry of electric conduction of human meridians. Bilaterally symmetrical acupoints provide better conductance for a better “connection”. *IEEE Eng Med Biol Mag* 18(1):76–78.
- Martinsen OG, Grimnes S, Morkrid L, Hareide M. 2001. Line patterns in the mosaic electrical properties of human skin—a cross-correlation study. *IEEE Trans Biomed Eng* 48(6):731–734.
- McCarroll GD, Rowley BA. 1979. An investigation of the existence of electrically located acupuncture points. *IEEE Trans Biomed Eng* 26(3):177–181.
- Motoyama H. 1986. Before polarization current and the acupuncture meridians. *J Holistic Med* 8(12):15–26.
- Motoyama H, Smith W, Harada T. 1984. Pre-polarization resistance of the skin as determined by the Single Square Voltage Pulse Method. *Psychophysiology* 21(5):541–550.
- Nakatani Y. 1956. Skin electric resistance and Ryodoraku. *J Autonomic Nerve* 6:52.
- Nakatani Y. 1986. *A Guide for Application of Ryodoraku Autonomous Nerve Regulatory Therapy*. Tokyo, Japan: Ryodoraku Institute. pp 1–25.
- Nakatani Y, Yamashita K. 1977. *Ryodoraku acupuncture*. Tokyo: Ryodoraku Research Institute. pp 1–12.
- Nansel DD, Jansen RD. 1988. Concordance between galvanic skin response and spinal palpation findings in pain-free males. *J Manipulative Physiol Ther* 11(4):267–272.
- Noordergraaf A, Silage D. 1973. Electroacupuncture. *IEEE Trans Biomed Eng* 20(5):364–366.
- Pearson S, Colbert AP, McNames J, Baumgartner M, Hammerschlag R. 2007. Electrical skin impedance at acupuncture points. *J Altern Complement Med* 13(4):409–418.
- Poon CS, Choy TT, Koide FT. 1980. A reliable method for locating electropermeable points on the skin surface. *Am J Chin Med* 8(3):283–289.
- Prokhorov E, Gonzalez-Hernandez J, Vorobiev YV, Morales-Sanchez E, Prokhorova TE, Zaldivar Lelo de Larrea G. 2000a. Electrophysical characterization of biologically active points and human skin by in vivo impedance measurement. Proceedings of the 22nd Annual EMBS International Conference: 2636–2639. Chicago, IL.
- Prokhorov EF, Gonzalez-Hernandez J, Vorobiev YV, Morales-Sanchez E, Prokhorova TE, Zaldivar Lelo de Larrea G. 2000b. In vivo electrical characteristics of human skin, including at biological active points. *Med Biol Eng Comput* 38(5):507–511.
- Prokhorov EF, Prokhorova TE, Gonzalez-Hernandez J, Kovalenko YA, Llamas F, Moctezuma S, Romero H. 2006. In vivo dc and ac measurements at acupuncture points in healthy and unhealthy people. *Complement Ther Med* 14(1):31–38.
- Reichmanis M, Marino AA, Becker RO. 1975. Electrical correlates of acupuncture points. *IEEE Trans Biomed Eng* 22(6):533–535.

- Reichmanis M, Marino AA, Becker RO. 1976. D.C. skin conductance variation at acupuncture loci. *Am J Chin Med* 4(1):69–72.
- Reichmanis M, Marino AA, Becker RO. 1977a. Laplace plane analysis of impedance between acupuncture points H-3 and H-4. *Comp Med East West* 5(3–4):289–295.
- Reichmanis M, Marino AA, Becker RO. 1977b. Laplace plane analysis of transient impedance between acupuncture points Li-4 and Li-12. *IEEE Trans Biomed Eng* 24(4):402–405.
- Reichmanis M, Marino AA, Becker RO. 1979. Laplace plane analysis of impedance on the H-meridian. *Am J Chin Med* 7(2):188–193.
- Roppel R, Mitchell FJ. 1975. Skin points of anomalously low electric resistance: Current-voltage characteristics and relationships to peripheral stimulation therapies. *JAOA* 74:159–160.
- Royal FF, Royal DF. 1991. A review of the history and scientific bases of electrodiagnosis and its relationship to homeopathy and acupuncture. *Am J Acupunct* 19(2):137–152.
- Shenberger RM. 1977. Acupuncture meridians retain their identity after death. *Am J Acupunct* 5(4):357–361.
- Wulfson NL, Warren FZ. 1976. Twenty-seven acupuncture points: Their electrical resistance 27. In: *Handbook of acupuncture*. New York, NY: Van Nostrand Reinhold Company. pp 65–74.
- Zhang W, Xu R, Zhu Z. 1999a. The influence of acupuncture on the impedance measured by four electrodes on meridians. *Acupunct Electrother Res* 24(3–4):181–188.
- Zhang W, Xu R, Zhu Z. 1999b. The influence of acupuncture on the impedance measured by four electrodes on meridians. *Acupunct Electrother Res* 24(3–4):181–188.
- Zhang WB, Jeong DM, Lee YH, Lee MS. 2004. Measurement of subcutaneous impedance by four-electrode method at acupoints located with single-power alternative current. *Am J Chin Med* 32(5):779–788.
- Zhu ZX, Xu RM, Xie JG, Yu SZ. 1984. Experimental Meridian Line of Stomach and Its Low Impedance Nature. *Acupunct Electrother Res* 9(3):157–164.
- Zhu ZX, Xu RM, Yue SY, Hao JK, Xie JG. 1988. The low impedance nature of meridian lines before and after amputation. *Br J Acupunct* 11(1):25–27.

[Q1](#): Please check the presentation of the tables.

[Q2](#): Please check the change made in the reference citations.

[Q3](#): Author name (Fraden) is not present in the reference list. Please check.

[Q4](#): Please specify whether it is 1999a or 1999b.

[Q5](#): Please provide citation in the reference list.

[Q6](#): Please provide citation in the reference list.

[Q7](#): Please provide citation in the reference list.

Bioelectromagnetics Society Membership Application Form

Please type:

Check Gender: Male Female

Salutation/Suffix: (Dr., Professor, Mr., Mrs., Miss, Ph.D., MD, PA, etc.)

Name:

Position Title:

Check Preferred Mailing Address (include city, state, zip, province, country):

Institutional Affiliation

Home

Institutional Affiliation & Address:

Home Address:

Telephone:

Work:

Fax:

Cell:

Email:

Highest Degree:

Field of Degree:

Awarded by University:

State your major areas of activity in bioelectromagnetics (e.g., genetics, medical, dosimetry):

If applying for Full Membership: On a separate sheet(s) of paper briefly outline your research interests or responsibilities in bioelectromagnetics. Attach a reference list of scientific papers, reports, presentations or curriculum vitae. ***Your application will not be processed until that material has been submitted to the BEMS office.***

If applying for Associate Membership: State why you are interested in becoming a member of the Society and provide appropriate support materials if available.

If applying as a Student, complete the following:

Name of School:

Department:

Advisor's Printed Name:

Advisor's Signature:

Advisor's Title:

MEMBERSHIP DUES (CHECK ONE)

SUSTAINING MEMBER (SM) ⁴	\$1,000.00	\$
FULL MEMBER (FM) ¹	\$ 85.00	\$
ASSOCIATE MEMBER (FA) ²	\$ 70.00	\$
STUDENT MEMBER (FS) ³	\$ 30.00	\$
EMERITUS MEMBER (FE) ⁵	\$ 30.00	\$

OR: PAY BOTH BEMS & EBEA MEMBERSHIP DUES

FULL MEMBERS	\$ 125.00	\$
ASSOCIATE MEMBERS	\$ 110.00	\$
STUDENT OR EMERITUS MEMBERS ..	\$ 45.00	\$

TOTAL MEMBERSHIP DUES\$

BIOELECTROMAGNETICS JOURNAL SUBSCRIPTION (CHECK ONE)

PRINT COPY AND ELECTRONIC ACCESS:

Sustaining member	\$ Complimentary	
North American member	\$ 85.00	\$
Canada add 7% G&S Tax	\$ 5.95	\$
North America Student	\$ 50.00	\$
Canada add 7% G&S Tax	\$ 3.50	\$
Outside North America member	\$ 105.00	\$
Outside North America Student	\$ 70.00	\$

OR: ELECTRONIC ACCESS (Worldwide) . \$ 75.00 \$
 Canada add 7% G&S Tax\$ 5.25 \$

TOTAL JOURNAL SUBSCRIPTION\$

GRAND TOTAL (Dues & Journal)\$

Signature & Date:

Please make checks payable to BEMS in U.S. dollars drawn on a U.S. bank or pay by credit card:

Visa, MasterCard, Diners Club or Discover #:

Expiration Date:

For Office Use Only: _____ **Computer Entry:** _____
 App. Ltr. Sent: _____ Membership Comm: _____ Notified: _____ Category: _____

PURPOSE

The Bioelectromagnetics Society (BEMS) is an international scientific society founded for the purpose of promoting research concerned with the interaction of electromagnetic energy with biological systems. This includes all such energies in the frequency range from DC to visible light.

To accomplish this purpose, the Society:

1. Publishes a journal of peer-reviewed papers.
2. Publishes a newsletter.
3. Holds an annual scientific meeting.
4. Sponsors symposia and workshops.
5. Publishes an annual membership directory.

The Society also provides its members with a number of services designed to enhance the exchange of scientific information and stimulate research.

ORGANIZATION

The Society is managed by an Executive Board and a Board of Directors who are elected by the voting members of the Society. The Board of Directors is chosen from representatives of the biological, medical, engineering and physical science communities within the Society. One-third of the Board and the President-elect are elected yearly. An Executive Director's Office provides members services and administers Society operations.

MEMBERSHIP

The Society has five (5) categories of membership:

1. FULL MEMBERS: All persons who are active in the field of bioelectromagnetics or allied areas, either through independent, original research, or by some other activity which has significantly fostered the development of the field, are eligible for full membership in the Society. Evidence of activity in the field could consist of one or more of the following:

- Publication of scientific papers or freely available reports in bioelectromagnetics;
- Presentation of research or clinical results at scientific meetings;
- Current involvement in research in bioelectromagnetics;
- Development of instrumentation for bioelectromagnetics research or clinical use;
- Or significant administration or management contribution to bioelectromagnetics.

Members may register at all scientific meetings of the Society at reduced rates and receive the Newsletter.

2. ASSOCIATE MEMBERS: Persons are eligible for Associate Membership who have an interest in bioelectromagnetics but whose professional activities are in other areas. Associate Members receive all the benefits of members except they may not vote or hold office.

3. STUDENT MEMBERS: Senior undergraduates and graduate students enrolled in a program of study leading to a degree in any of the fields related to bioelectromagnetics are eligible to become Student Members of the Society. Student Members have the same privileges as Associate Members.

4. SUSTAINING MEMBERS: A person or corporation may be elected a Sustaining Member by the Board of Directors on the basis of activities which further the Society or its purposes. Sustaining Members are accorded special recognition and benefits.

5. EMERITUS/RETIRED MEMBERS: A person who fulfills Full Member/Associate Member requirements but has become Emeritus or has retired from his/her institution.

MEETINGS

The Society sponsors an Annual Scientific Meeting. Topical workshops, symposia and other international meetings are also sponsored, often in cooperation with allied organizations which share similar research interests.

PUBLICATIONS

BIOELECTROMAGNETICS, the Society's journal, is published bi-monthly. This journal is devoted to research exploring the interaction of biological systems with electromagnetic fields having frequencies from DC to visible light. The journal publishes peer-reviewed papers in the following general areas:

- Responses of biological systems to electromagnetic environments;
- Mechanisms and models of the interaction of electromagnetic fields with biological systems;
- Absorption and distribution of electromagnetic energy within biological systems, and diagnostic and therapeutic uses of electromagnetic radiation and fields.

Concise critical reviews of current research and issues on special topics are also published from time to time. BEMS members receive a greatly reduced subscription rate for the journal.

The **Bioelectromagnetics Society Newsletter** is published and distributed to all members of the Society. It includes news of the Society and its members, topical articles on current research, bibliographical citations, news of governmental regulations, information on research support, letters, and job information. The Newsletter is of interest to those involved in bioelectromagnetics research, including health issues.

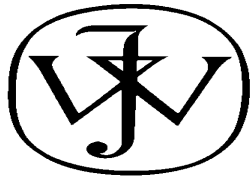

WILEY

Publishers Since 1807

REPRINT BILLING DEPARTMENT • 111 RIVER STREET • HOBOKEN, NJ 07030
FAX: (201) 748-7670
E-MAIL: reprints@wiley.com

PREPUBLICATION REPRINT ORDER FORM

Please Complete this form if you wish to order reprints prior to publication. This form **MUST** be returned by with your corrected proofs. Your reprints will be shipped approximately 4 to 6 weeks after publication. Reprints ordered after printing are substantially more expensive.

JOURNAL Bioelectromagnetics (BEM) VOLUME _____ ISSUE _____
TITLE OF MANUSCRIPT _____
MS. NO. _____ NO. OF PAGES _____ AUTHOR (S) _____

No. of Pages	100 Reprints	200 Reprints	300 Reprints	400 Reprints	500 Reprints
	\$	\$	\$	\$	\$
1-4	336	501	694	890	1,052
5-8	469	703	987	1,251	1,477
9-12	594	923	1,234	1,565	1,850
13-16	714	1,156	1,527	1,901	2,273
17-20	794	1,340	1,775	2,212	2,648
21-24	911	1,529	2,031	2,536	3,037
25-28	1,004	1,707	2,267	2,828	3,388
29-32	1,108	1,894	2,515	3,135	3,755
33-36	1,219	2,092	2,773	3,456	4,143
37-40	1,329	2,290	3,033	3,776	4,528

** REPRINTS ARE ONLY AVAILABLE IN LOTS OF 100. IF YOU WISH TO ORDER MORE THAN 500 REPRINTS, PLEASE CONTACT OUR REPRINTS DEPARTMENT AT (201) 748-8789 FOR A PRICE QUOTE.

◆ Please send me _____ reprints of the above article at \$ _____
Please add appropriate State and Local Tax {Tax Exempt No. _____} \$ _____
Please add 5% Postage and Handling \$ _____
TOTAL AMOUNT OF ORDER ** \$ _____
*** International orders must be paid in U.S. currency and drawn on a U.S. bank*

Please check one: Check Enclosed Bill Me Credit Card
If credit card order, charge to: American Express Visa MasterCard Discover

Credit Card No. _____ Signature _____ Exp. Date _____

Bill To:
Name _____
Address _____

Purchase Order No. _____

Ship To:
Name _____
Address _____

Phone _____ Fax _____
E-mail _____

COPYRIGHT TRANSFER AGREEMENT

Date:

Production/Contribution

ID# _____

To:

Publisher/Editorial office use only

Re: Manuscript entitled _____
_____ (the "Contribution")
for publication in _____ (the "Journal")
published by Wiley-Liss, Inc., a subsidiary of John Wiley & Sons, Inc. ("Wiley").

Dear Contributor(s):

Thank you for submitting your Contribution for publication. In order to expedite the publishing process and enable Wiley to disseminate your work to the fullest extent, we need to have this Copyright Transfer Agreement signed and returned to us as soon as possible. If the Contribution is not accepted for publication this Agreement shall be null and void.

A. COPYRIGHT

1. The Contributor assigns to Wiley, during the full term of copyright and any extensions or renewals of that term, all copyright in and to the Contribution, including but not limited to the right to publish, republish, transmit, sell, distribute and otherwise use the Contribution and the material contained therein in electronic and print editions of the Journal and in derivative works throughout the world, in all languages and in all media of expression now known or later developed, and to license or permit others to do so.
2. Reproduction, posting, transmission or other distribution or use of the Contribution or any material contained therein, in any medium as permitted hereunder, requires a citation to the Journal and an appropriate credit to Wiley as Publisher, suitable in form and content as follows: (Title of Article, Author, Journal Title and Volume/Issue Copyright © [year] Wiley-Liss, Inc. or copyright owner as specified in the Journal.)

B. RETAINED RIGHTS

Notwithstanding the above, the Contributor or, if applicable, the Contributor's Employer, retains all proprietary rights other than copyright, such as patent rights, in any process, procedure or article of manufacture described in the Contribution, and the right to make oral presentations of material from the Contribution.

C. OTHER RIGHTS OF CONTRIBUTOR

Wiley grants back to the Contributor the following:

1. The right to share with colleagues print or electronic "preprints" of the unpublished Contribution, in form and content as accepted by Wiley for publication in the Journal. Such preprints may be posted as electronic files on the Contributor's own website for personal or professional use, or on the Contributor's internal university or corporate networks/intranet, or secure external website at the Contributor's institution, but not for commercial sale or for any systematic external distribution by a third party (e.g., a listserve or database connected to a public access server). Prior to publication, the Contributor must include the following notice on the preprint: "This is a preprint of an article accepted for publication in [Journal title] © copyright (year) (copyright owner as specified in the Journal)". After publication of the Contribution by Wiley, the preprint notice should be amended to read as follows: "This is a preprint of an article published in [include the complete citation information for the final version of the Contribution as published in the print edition of the Journal]", and should provide an electronic link to the Journal's WWW site, located at the following Wiley URL: <http://www.interscience.Wiley.com/>. The Contributor agrees not to update the preprint or replace it with the published version of the Contribution.
2. The right, without charge, to photocopy or to transmit online or to download, print out and distribute to a colleague a copy of the published Contribution in whole or in part, for the Contributor's personal or professional use, for the

advancement of scholarly or scientific research or study, or for corporate informational purposes in accordance with Paragraph D.2 below.

3. The right to republish, without charge, in print format, all or part of the material from the published Contribution in a book written or edited by the Contributor.
4. The right to use selected figures and tables, and selected text (up to 250 words, exclusive of the abstract) from the Contribution, for the Contributor's own teaching purposes, or for incorporation within another work by the Contributor that is made part of an edited work published (in print or electronic format) by a third party, or for presentation in electronic format on an internal computer network or external website of the Contributor or the Contributor's employer.
5. The right to include the Contribution in a compilation for classroom use (course packs) to be distributed to students at the Contributor's institution free of charge or to be stored in electronic format in datarooms for access by students at the Contributor's institution as part of their course work (sometimes called "electronic reserve rooms") and for in-house training programs at the Contributor's employer.

D. CONTRIBUTIONS OWNED BY EMPLOYER

1. If the Contribution was written by the Contributor in the course of the Contributor's employment (as a "work-made-for-hire" in the course of employment), the Contribution is owned by the company/employer which must sign this Agreement (in addition to the Contributor's signature), in the space provided below. In such case, the company/employer hereby assigns to Wiley, during the full term of copyright, all copyright in and to the Contribution for the full term of copyright throughout the world as specified in paragraph A above.
2. In addition to the rights specified as retained in paragraph B above and the rights granted back to the Contributor pursuant to paragraph C above, Wiley hereby grants back, without charge, to such company/employer, its subsidiaries and divisions, the right to make copies of and distribute the published Contribution internally in print format or electronically on the Company's internal network. Upon payment of the Publisher's reprint fee, the institution may distribute (but not resell) print copies of the published Contribution externally. Although copies so made shall not be available for individual re-sale, they may be included by the company/employer as part of an information package included with software or other products offered for sale or license. Posting of the published Contribution by the institution on a public access website may only be done with Wiley's written permission, and payment of any applicable fee(s).

E. GOVERNMENT CONTRACTS

In the case of a Contribution prepared under U.S. Government contract or grant, the U.S. Government may reproduce, without charge, all or portions of the Contribution and may authorize others to do so, for official U.S. Government purposes only, if the U.S. Government contract or grant so requires. (U.S. Government Employees: see note at end).

F. COPYRIGHT NOTICE

The Contributor and the company/employer agree that any and all copies of the Contribution or any part thereof distributed or posted by them in print or electronic format as permitted herein will include the notice of copyright as stipulated in the Journal and a full citation to the Journal as published by Wiley.

G. CONTRIBUTOR'S REPRESENTATIONS

The Contributor represents that the Contribution is the Contributor's original work. If the Contribution was prepared jointly, the Contributor agrees to inform the co-Contributors of the terms of this Agreement and to obtain their signature to this Agreement or their written permission to sign on their behalf. The Contribution is submitted only to this Journal and has not been published before, except for "preprints" as permitted above. (If excerpts from copyrighted works owned by third parties are included, the Contributor will obtain written permission from the copyright owners for all uses as set forth in Wiley's permissions form or in the Journal's Instructions for Contributors, and show credit to the sources in the Contribution.) The Contributor also warrants that the Contribution contains no libelous or unlawful statements, does not infringe on the rights or privacy of others, or contain material or instructions that might cause harm or injury.

CHECK ONE:

Contributor-owned work

Contributor's signature

Date

Type or print name and title

Co-contributor's signature

Date

Type or print name and title

ATTACHED ADDITIONAL SIGNATURE PAGE AS NECESSARY

Company/Institution-owned work
(made-for-hire in the
course of employment)

Company or Institution (Employer-for-Hire)

Date

Authorized signature of Employer

Date

U.S. Government work

Note to U.S. Government Employees

A Contribution prepared by a U.S. federal government employee as part of the employee's official duties, or which is an official U.S. Government publication is called a "U.S. Government work," and is in the public domain in the United States. In such case, the employee may cross out Paragraph A.1 but must sign and return this Agreement. If the Contribution was not prepared as part of the employee's duties or is not an official U.S. Government publication, it is not a U.S. Government work.

U.K. Government work (Crown Copyright)

Note to U.K. Government Employees

The rights in a Contribution prepared by an employee of a U.K. government department, agency or other Crown body as part of his/her official duties, or which is an official government publication, belong to the Crown. In such case, the Publisher will forward the relevant form to the Employee for signature.